

ENTRANCES

SERIES 250, 400 & 550 DOORS

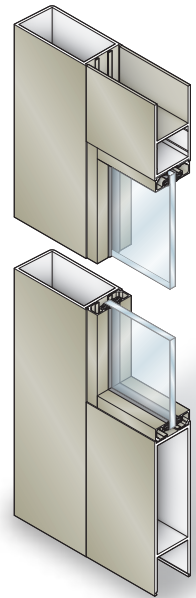

- Lifetime warranty on corner construction
- Mechanically fastened and welded corners
- Narrow, Medium & Wide Styles
- Adjustable weatherstrip astragal at meeting stiles
- Accommodates most custom hardware
- Standard 1" diameter solid push/pulls



Our entrance doors are consistently built to the highest industry standards, ensuring years of reliable service. All doors are supplied with push/pull hardware, maximum security locks and easily accommodate a wide variety of custom hardware for specific job requirements.



SERIES 250, 400 and 550 Entrance Doors

TYPICAL DETAILS

SERIES 250

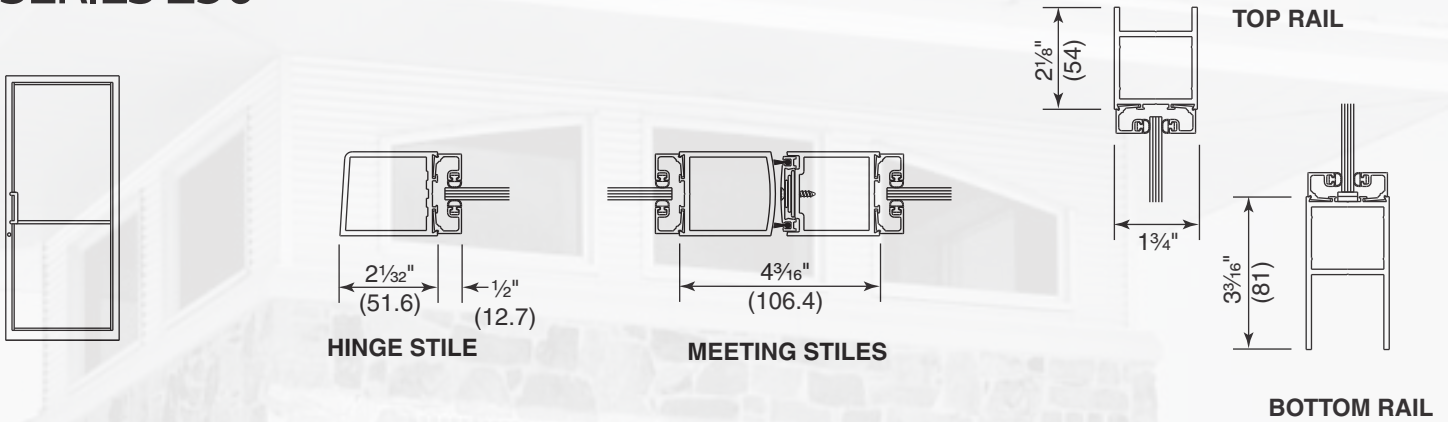

SERIES 400

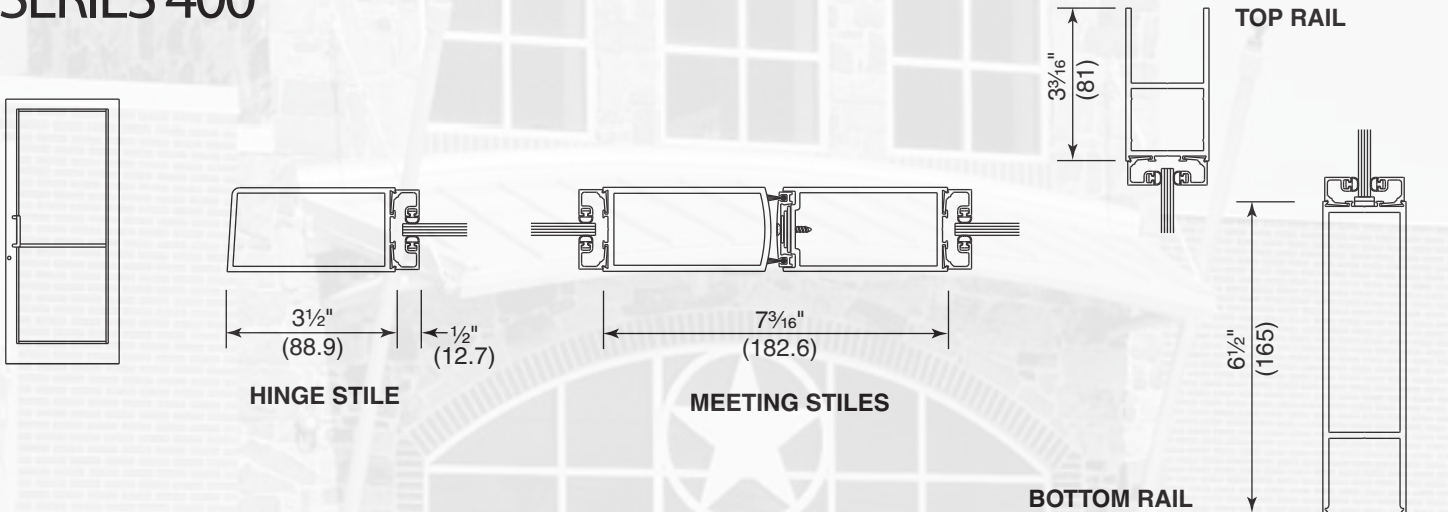

SERIES 550

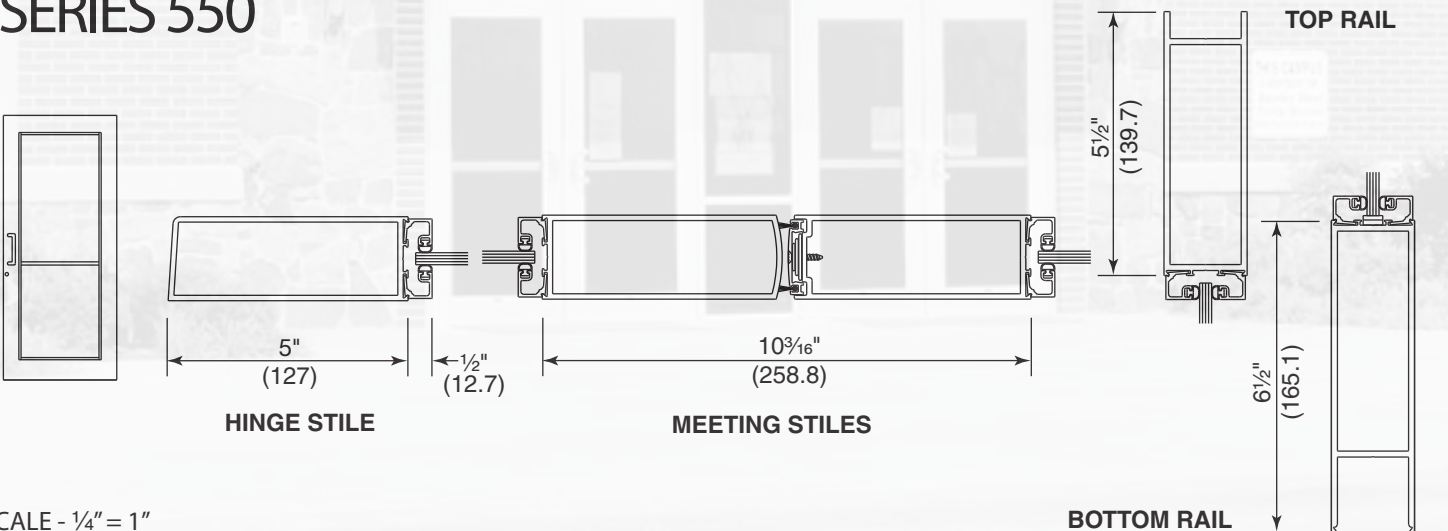

SCALE - $\frac{1}{4}" = 1"$



California - 800.766.6063
 Chicago - 800.323.8480
 Texas - 800.627.6440

South Carolina - 800.462.5668
 Canada BC - 888.889.3899
 Canada Ont. - 800.796.6636